

**TECHNICAL SPECIFICATIONS  
FOR PROCUREMENT OF BOTTOM RESTING UNIT (BRU)**

1. Refer to: RFP No: BM(H)/CMM/RFP/25-26/2123, Date: 17 Jan 2026
2. **Description:** Bottom Resting Unit (BRU) is manufacture assembly of shell and dish end using M12 fasteners. The system is utilized in Inclined launcher system at TP. The schematic drawing is shown in fig 1.1 below:

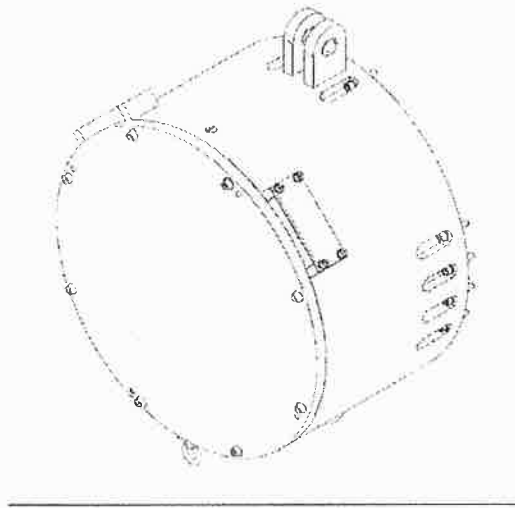

Fig 1.1

**3. Scope of work:**

- A. Manufacturing of BRU assembly as per draft QA plan and guidance manufacturing drawings. The reference QA plan and drawings will be shared by BAPL.
- B. Vendor shall prepare final QAP/production drawings considering draft QAP/drawings as reference/guidance and shall submit to BAPL for approval.
- C. The work includes training of Indian Navy nominated officers for duration of 10 working days.
- D. Vendor should provide Repairs only, during O&M warranty and CAMC for three years post expiry of warranty. The warranty should be for period of two years.

**4. List of deliverables**

The vendor has to supply the following as part of the order:

Sl. No.	Item Description	Reference Drawing no.	Item code	Quantity
1	Bottom Resting Unit with fasteners	Post signing of NDA	200410100700	02 no.
2	Standard tool set	-	-	01 set (Details to be shared by vendor)
3	MRLS	-	-	02 set (Details to be shared by Vendor)
4	Technical/operational/Maintenance Manual	-	-	02 set (Hard/Soft copies)

Table 1: List of deliverables

**5. Technical Specifications**

**A. Manufacturing drawing**

- (i) Manufacturing to be as per guidance drawing. The detailed production drawing generation in AutoCAD / Hard copy (as required by End User) and manufacturing process sheets should be submitted to BrahMos for approval.
- (ii) The production quality / acceptance and testing / painting specification should be as per approved Quality Assurance Plan (QAP). The details of QAP will be worked out jointly between vendor and BAPL. QA plan will include raw material testing (physical and chemical properties), welding qualifications, NDT stage inspection etc.

\*BAPL will be the inspection agency for the deliverables and any dimensional/machining deviation is not recommended post finalization of drawings.

**B. Acceptance testing**

BAPL will be the QA agency for manufacturing/acceptance of deliverables and any dimensional/machining deviation is not recommended post finalization of drawings.

**6. PDI / JRI**

- A. Pre-Delivery Inspection (PDI) will be carried out by M/s BAPL at vendor premises.
- B. Joint Receipt Inspection (JRI) will be carried out jointly by M/s BAPL, supplier and Rep of OTP Tunir at INS Tunir.

**7. Marking and Packing**

The deliverables shall be packed in wooden boxes/suitable container with supports for storage and transportation as per Def. standard norms.

**8. Delivery schedule and location**

- A. The item to be supplied within **12 months** from the date of issue of purchase order (Tentatively by 30 Dec 2026)
- B. Deliverables to be packed/ preserved and transported by the supplier to OTP Tunir.

A handwritten signature in black ink, appearing to read 'Surya Shankar', is located in the bottom right corner of the page.